



# BD-2 Series

## Exhaust Only Hood

CaptiveAire's Premier Low Proximity Hood

**The BD-2 Series is a Type I, Low Proximity Hood for use over 450°F and 600°F cooking surface temperatures. The Low Proximity Hood, also called Backshelf hood, refers to the close location of the hood with respect to the cooking appliances.**

---

### Fully Integrated Package

CaptiveAire sells this hood as a stand-alone appliance to be integrated into a kitchen ventilation application, or provided as part of a FULLY INTEGRATED PACKAGE designed by CaptiveAire and pre-engineered for optimum performance. The package consists of the hood, an integral utility cabinet, factory pre-wired electrical controls, and a listed fire suppression system. Other options include a listed exhaust fan, a listed make-up air unit and listed, factory-built ductwork.



---

## Advantages

- ▶ **Exhaust Flow Rates:** Superior exhaust flow rates.
- ▶ **ETL Listed:** ETL Listed for use over 450°F and 600°F cooking surface temperatures, which provides flexibility in designing kitchen ventilation systems. ETL Listed to US and Canadian safety standards, ETL Sanitation Listed and built in accordance with NFPA 96.
- ▶ **Capture and Containment:** Unique front design directs grease laden vapors toward the exhaust filter bank. Double-wall, insulated front increases rigidity and reduces condensation on models 30 inch width and larger.
- ▶ **Convenient Design:** Fitted with UL Listed, pre-wired, incandescent light fixtures and tempered glass globes to hold up to a standard 100 watt bulb; not included on 24 or 26 inch widths. Pre-punched hanging angles on each end of hood and additional set provided for hoods longer than 12'. Space saving, compact design uses limited kitchen space (24" minimum width).
- ▶ **Construction:** Fabricated of Type 430 stainless steel, #3 or #4 polish, on all exposed surfaces. Optional type 304 stainless steel available. Fully welded and polished front corners. Built in air space to meet NFPA 96 clearance requirements against limited combustible wall with optional insulation for combustible wall.
- ▶ **Controls:** Hoods can be equipped with modular utility cabinets and end standoffs. A built-in wiring chase provided for optimal positioning of electrical controls and outlets on front face of hood without penetrating capture area or requiring sleeve; available on 30" wider and larger models.
- ▶ **Grease Extraction:** All hoods come standard with stainless steel baffle filters and a deep grease trough which allows for easy cleaning. Captrate Combo® and Captrate Solo® filters are optional. Grease drain system with removable 1/2 pint cup for easy cleaning. Standard filter stops eliminate gaps between filters.
- ▶ **Reduced Lead Times and Shipping Costs:** Produced on a high volume assembly line at one of five manufacturing facilities to reduce lead times and shipping costs.
- ▶ **Optional Make-Up Air:** Make-up air can be supplied through optional front plenums (ND-2 Series with PSP or AC-PSP Accessory)
- ▶ **Optional Self Cleaning Technology:** The Self Cleaning Hood option adds a spray bar that extends the full length of the hood immediately behind the filters. The system cleans grease from the plenum and portion of the duct with the daily hot water spray cycle.
- ▶ **Optional CORE Protection:** The CORE Fire Protection System is an automatic, pre-engineered fire suppression system which is ETL listed to UL Standard 300. The CORE Protection System is designed to provide primary coverage for ventilating equipment including hoods, ducts, plenum and filters.

---

## Performance

AVG. COOKING SURFACE TEMP. (°F)	MIN. EXHAUST CFM/FT.
450°F	150
600°F	200

**Recommended Duct Sizing:** Exhaust - Based on 1500 FPM

---

## Features

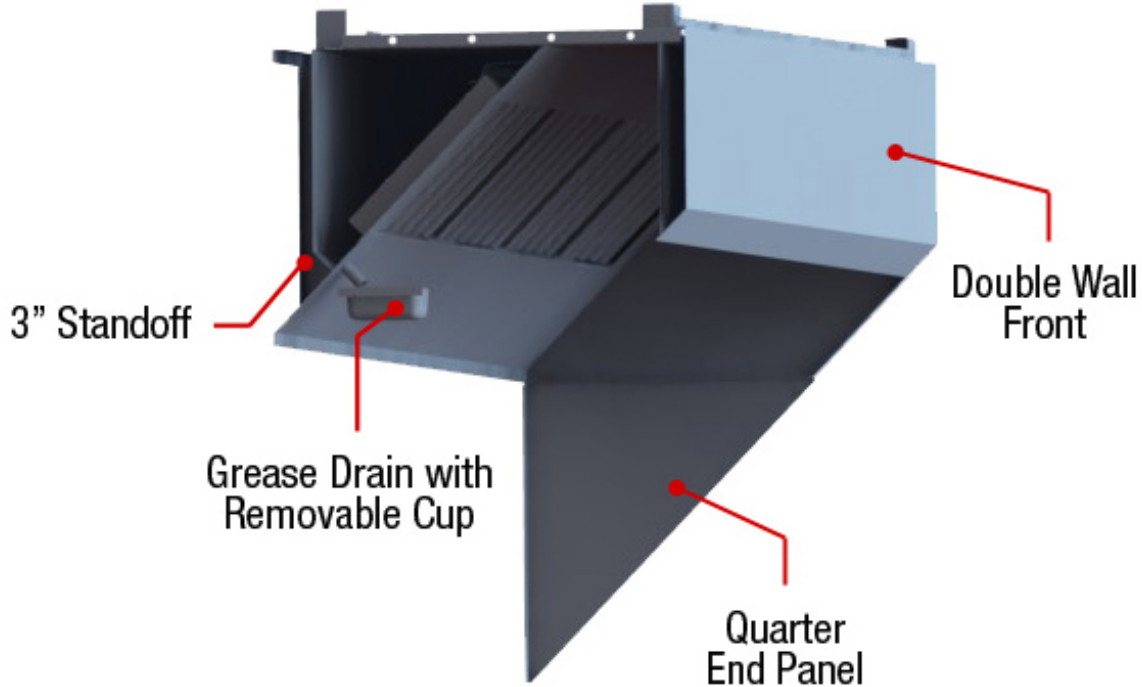

---

## Options

**Utility Cabinet:** Listed for integral side mount and fabricated of same material as hood. Cabinet can house listed fire suppression system and listed, pre-wired electrical controls.

**Front Perforated Supply Plenum:** Provides low velocity make-up air for the kitchen and is discharged in front of the hood. Perforated diffuser plates allow for even air distribution and supply riser includes a volume damper for easy balancing.

**Enclosure Panels:** Constructed of stainless steel. Sized to extend from hood top to ceiling, enclosing pipe and hanging parts.

**Roof Top Package:** Combination ETL Listed exhaust/supply air unit with factory prewired and mounted motors, trunkline and curb vented on exhaust side.

**Separate Exhaust and/or Make-Up Air Fans:** ETL Listed single exhaust fans, supply-air fans and curbs available.

**Fire Suppression System:** UL 300 fire suppression system.

**Lighting:** Compact Fluorescent or Halogen

---

## Certifications

The BD-2 Model has been certified by ITS. This certification mark indicates that the product has been tested to and has met the minimum requirements of a widely recognized (consensus) U.S. and Canadian products safety standard, that the manufacturing site has been audited, and that the applicant has agreed to a program of periodic factory follow-up inspections to verify continued performance.

Models BD-2 are ETL Listed under file number 3054804-001 and complies with UL710, ULC710 and ULC-S646 Standards.

