



## POT & PAN

Chemical Sanitizing  
Pot & Pan Single Rack  
Straight/Corner Dishwasher



Corner Model



AH Model



SB Model

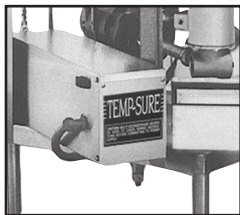

Optional Temp-Sure™ heater assures a continuous supply of 140°F hot water that guarantees excellent results.

### FEATURES:

- 40 racks / 160 covers per hour.  
Models AH & C
- 80 racks / 320 covers per hour.  
Model SB
- All stainless steel construction assures long life and years of trouble free operation.
- Unique spray arm system features upper and lower stainless steel wash arms with reinforced end caps. Specially designed pull-pins allow wash arms to be easily removed for cleaning.
- Pump purging system improves results by eliminating soil and chemical carryover during rinse cycle.
- Top mounted controls include built-in chemical pumps and deliming system that assures proper chemical usage.
- Auto start/stop makes operation safe and easy.
- Large 27" high door opening accommodates larger items and utensils.
- Integrated scrap tray prevents food soil from entering drain system.
- Stainless steel impeller offers extended life and service.
- Built-in strainer in water inlet to prevent water valve from clogging.

### Available Options

- Solid/Powder Dual Bowl Dispenser
- CMA Temp-Sure™  
(Self contained 12kW heater)
- Sanitizer Alarm
- Stainless Steel Dishtables
- Alternative Cycle Times
- Alternative Electrical Available for Export
- Stainless Steel Scrap Trap Upgrade
- Slant Shelf 27"X42"
- Sheet Pan Dish Rack

**CMA  
MIZER®**  
Registered Trademark





# POT & PAN

Chemical Sanitizing  
Pot & Pan Single Rack  
Dishwasher

## WARNINGS:

- Plumbing connections must be made by a qualified service company who will comply with all available Federal, State, and Local Health, Plumbing and Safety codes.
- CMA recommends utilizing a water softening system to maintain water hardness measurements of 3.5 gpg (grains per gallon) or less. This will assure maximum results and optimum operation of the dishmachine.

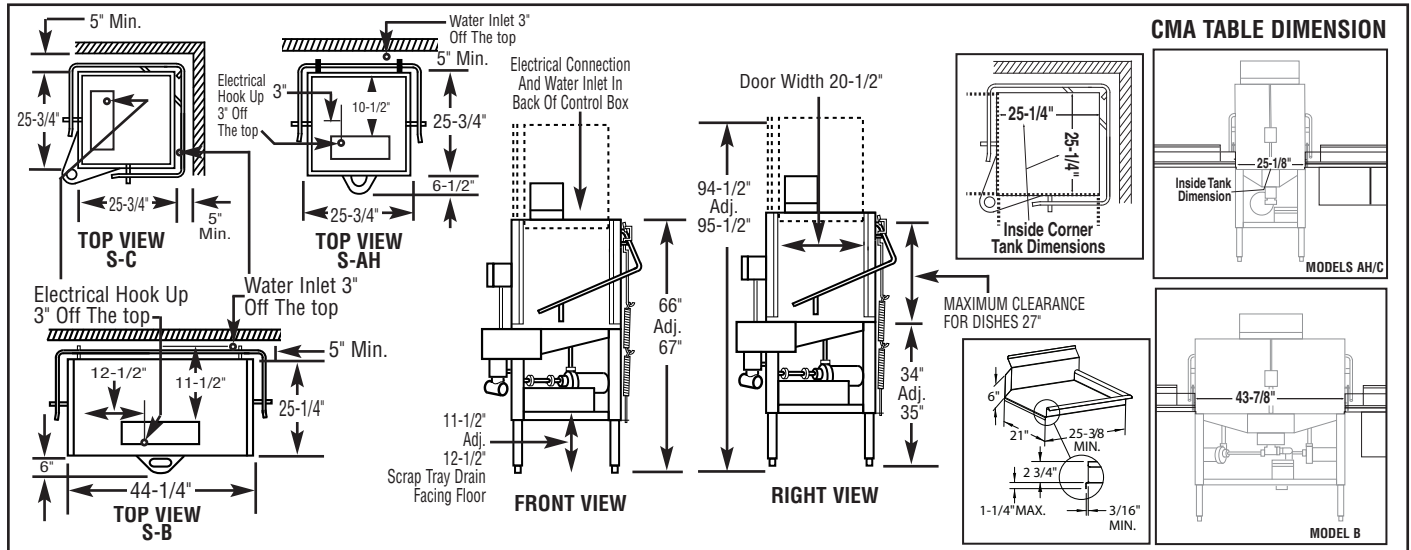

## Specifications:

MODEL S	USA	METRIC	USA	METRIC
<b>OPERATING CAPACITY</b> RACKS PER HOUR (NSF RATED)	40	40	<b>WASH PUMP MOTORS HP</b>	1
<b>OPERATING CYCLE</b> WASH TIME-SEC	45	45	<b>DIMENSIONS</b> DEPTH	25-3/4" (AH/C) (65.4cm)
RINSE TIME-SEC	30	30	DEPTH	25-1/4" (B) (64cm)
DWELL TIME-SEC	15	15	WIDTH (OUTSIDE DIMINION)	25-3/4" (AH/C) (65.4cm)
TOTAL CYCLE TIME	90	90	WIDTH (OUTSIDE DIMINION)	44-1/4" (B) (112cm)
WASH TANK CAPACITY	1.7 GAL. (AH/C) 3.0 GAL (B)	(6.43 L) (11.4 L)	HEIGHT	66"-67" (168-170cm)
PUMP CAPACITY	68 GPM (AH/C) 136 GPM (B)	(257 LPM) (514.7 LPM)	STANDARD TABLE HEIGHT	34" (86cm)
<b>OPERATING TEMPERATURE</b> REQUIRED	120°F	(49°C)	MAXIMUM CLEARANCE FOR DISHES	27" (68.5cm)
RECOMMENDED	140°F	(60°C)	DRAIN CONNECTION (OFF FLOOR)	11-1/2" - 12-1/2" (29.2cm - 31.7cm)
<b>WATER CONSUMPTION</b> PER RACK	1.7 GAL. (AH/C)	(6.43 L)	<b>STANDARD DISHRACK</b> DIMENSIONS	1 19-3/4"X19-3/4" (50X50cm)
PER RACK	3.0 GAL (B)	(11.3 L)	<b>ELECTRICAL RATING</b>	<b>VOLTS</b> 115 (AH/C) 115 (B)
PER HOUR	74 GPH (AH/C)	(280 LPH)	<b>AMPS</b>	16 (AH/C) 30 (B)
PER HOUR	118.4 GPH (B)	(448 LPH)	<b>APPROXIMATE SHIPPING WEIGHT</b>	299# A/C 397# B (135.6kg) (180.kg)
<b>WATER REQUIREMENTS</b> WATER INLET	3/4"	(1.9cm)	<b>SHIPPING DIMENSIONS</b>	PALLET & BOX @ 41" X 41" X 80" (A/C) PALLET & BOX @ 51" X42" X 65" (B)
DRAIN-I.P.S.	2"	(5.1cm)		

## Summary Specifications: Model S

CMA Energy Miser model S low temperature, chemical sanitizing commercial dishwasher meets NSF and UL sanitation and construction standards WITHOUT the use of BOOSTER or TANK HEATERS. The model S is constructed entirely of stainless steel. Each unit automatically washes, rinses and sanitizes food service utensils in standard 19-3/4" x 19-3/4" racks and accommodates oversized plates and utensils with a 27" high door clearance. Unit comes standard with upper and lower stainless steel wash arms. The model S incorporates a pump purging system that improves results by eliminating soil and chemical carryover during rinse cycle. **Note: This machine does not have built-in heaters, therefore produces no steam.**

**Available Models:** ■ S-AH Straight ■ S-C Corner ■ S-B

**Advisory:** CMA does NOT endorse "Tankless On-Demand" water heaters for use on CMA Dishmachine products. CMA DOES endorse, and highly recommends, the standard "tank" style water heaters, sized properly to handle each particular facility with their water heating requirements.



**CMA MIZER**  
Registered Trademark

CMA Dishmachines 12700 Knott Street Garden Grove, CA 92841 • 800-854-6417 • 714-898-8781 • Fax: 714-895-2141 • www.cmadishmachines.com

CMA reserves the right to modify specifications or discontinue models without prior notification.

PN: 10106.00

© 8-2018 CMA, Inc.

an Ali Group Company



The Spirit of Excellence