



Job: \_\_\_\_\_

Item No. \_\_\_\_\_

## DESIGNED FOR MEDIUM VOLUME APPLICATIONS

Four – 4 oz. Servings per Minute per side and 11 Quart Capacity per side

IDEAL FOR RESTAURANTS, CONCESSIONAIRES AND AMUSEMENT PARKS

The **SaniServ**® model 501 Soft Serve Freezer is a favorite in providing versatility to serve two individual flavors as well as a flavor twist. The 501 offers high profit, consistent quality soft serve and yogurt products in a popular countertop design. Two independent flavor reservoirs and barrels guarantee separation of product and flavors. Touch controls allow for ease of operation with built in stand by mode and universal symbols for freeze and clean insures the 501 as a favorite among operators while providing customers the popular flavor twist they enjoy!

# Model 501

Counter Model  
**Twist Soft Serve**  
Ice Cream / Yogurt Machine  
With **AccuFreeze™** Control

### NEW SCROLL COMPRESSOR

Provides the **SaniServ**® Model 501 with quieter operation. It is 20% more efficient. Increased durability, with 50% longer service life.

### SPACE SAVING

**Small Footprint Design - SaniServ**® model 501 saves valuable floor space and turns the countertop into a real profit center.

### EASY CLEANING AND OPERATION

**Fewer Parts = Simplified Cleaning – SaniServ**® equipment is designed and built with the fewest parts to be disassembled, cleaned and sanitized than any other machine in the industry. The state of the art solid-state **Touch AccuFreeze™** control insures product consistency, worry free operation and customer satisfaction.

### HIGH RETURN ON INVESTMENT

**Increased Profits – SaniServ**® machines combine efficiency with consistent product quality and fast, quiet operation while insuring customer satisfaction with high profit ice cream or yogurt products.

### QUALITY DESIGN

**Durability – SaniServ**® machines are built to achieve long and dependable life through simplicity of design. Every machine is shipped standard with a stainless steel exterior, durable steel interior frame construction, heavy-duty components and consistency systems.



Made in USA

We reserve the right to change specifications and product designs without notice. Such revisions do not entitle the buyer to corresponding changes, improvements, additions or replacements for previously purchased equipment.

# MODEL 501

## Counter Model *Twist* Soft Serve/Yogurt Freezer

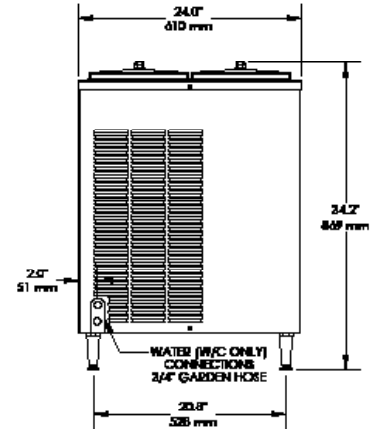
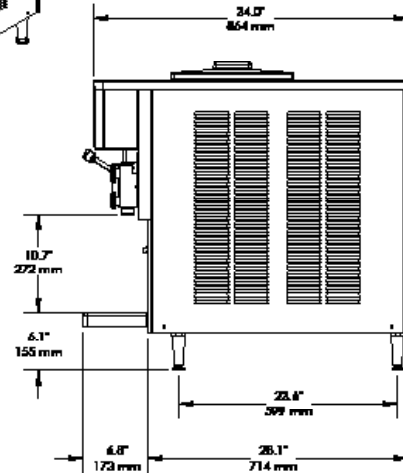
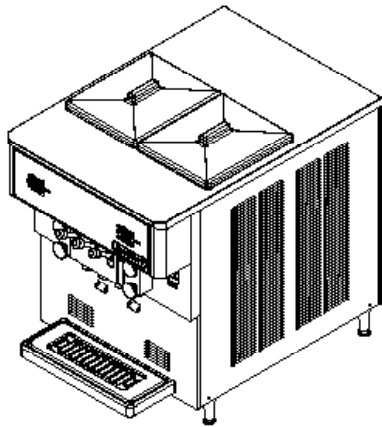

Minimum Wall Clearance  
Both Sides and Back -  
6 inches (152 mm)

ELECTRICAL				WIDTH	HEIGHT	DEPTH	WEIGHT	VOLUME
VOLTS	Hz	Ph.	Amps	INCHES (MM)	INCHES (MM)	INCHES (MM)	LBS. (Kg)	CU FT. (cu. m.)
208-230	60	1	30	24 (610)	33.1 (826)	32 (813)	400 (182)	
208-230	60	3	25					
Shipping Specifications				31.5 (800)	40.5 (1029)	40.5 (1029)	470 (214)	28.4 (.79)

### Specifications:

#### Cooling System:

Air or Water

#### Dasher and Compressor Motors:

(2) 1 HP Dashers  
(1) 2 HP Scroll Compressor

#### Refrigerant Type:

R404A

#### Listings:

UL, cUL, NSF

### Features:

#### Evaporator and Mix Reservoir

#### Capacity:

11 Quarts (10.4 liters) per side

#### Dasher:

Heavy-Duty Stainless Steel with low friction scraper blades.

#### Controls:

**Touch AccuFreeze™**  
solid-state control for accurate product consistency.

#### Solid State Audio/Visual Mix Out System with Compressor Lockout

### Warranty:

Parts 1 year  
Compressor 5 years  
Evaporator 5 years

### Options:

Tune Up Kit  
Parts Tray  
Syrup Rail  
Counter Top Mounting Pad  
Machine Stand  
Water Cooled - 3/4" Garden  
Hose Fitting  
Wash Out Kit - 3/8" Flare Fitting