



Job: \_\_\_\_\_

Item No. \_\_\_\_\_

## DESIGNED FOR HIGHER VOLUME APPLICATIONS

Five – 4 oz. Servings per Minute per side and 17 Quart Capacity per side

IDEAL FOR SELF-SERV BUFFETS, CAFETERIAS, QUICK SERVICE RESTAURANTS

The **SaniServ** model 521 Soft Serve Freezer provides the highest volume of two individual flavors as well as a flavor twist. The 521 offers the highest volume of high profit, consistent quality soft serve and yogurt products in the **SaniServ** product lineup. Two large independent flavor product reservoirs and barrels guarantee separation of product and flavors. Large product capacity and quick recovery time insure customers receive their favorite flavors individually or with a twist!

### SPACE MAXIMIZING

**Traditional Floor Model Design - SaniServ** model 521 turns valuable floor space into a real profit center by serving the highest volume of two high profit ice cream and yogurt product flavors along with the ability to twist the flavors into a frozen favorite.

### EASY CLEANING AND OPERATION

**Fewer Parts = Simplified Cleaning – SaniServ** equipment is designed and built with the fewest parts to be disassembled, cleaned and sanitized than any other machine in the industry. The state of the art solid-state **Touch AccuFreeze** control insures product consistency, worry-free operation and customer satisfaction.

### HIGH RETURN ON INVESTMENT

**Increased Profits – SaniServ** machines combine efficiency with consistent product quality and fast, quiet operation while insuring customer satisfaction with high profit ice cream or yogurt products.

### QUALITY DESIGN

**Durability – SaniServ** machines are built to achieve long and dependable life through simplicity of design. Every machine is shipped standard with a stainless steel exterior, durable steel interior frame construction, heavy-duty components and consistency systems.

# Model 521

Floor Model  
**Twist Soft Serve**  
Ice Cream / Yogurt Machine  
With **AccuFreeze Control**



Made in USA

We reserve the right to change specifications and product designs without notice. Such revisions do not entitle the buyer to corresponding changes, improvements, additions or replacements for previously purchased equipment.

451 E. County Line Rd. • P.O. Box 1089 • Mooresville, IN 46158  
Toll Free 800-733-8073 • Local 317-831-7030 • Fax 317-831-7036  
[www.saniserv.com](http://www.saniserv.com)

# MODEL 521

## Floor Model *Twist Soft Serve/Yogurt Freezer*

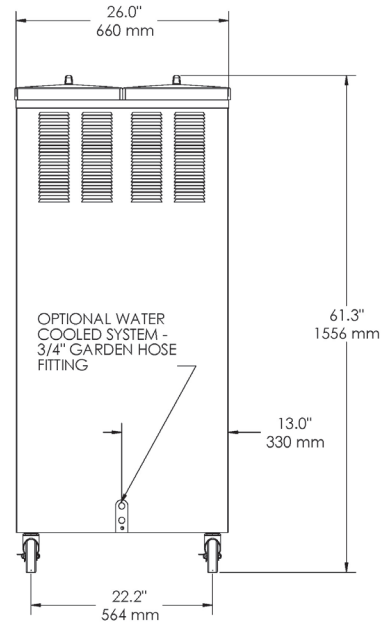
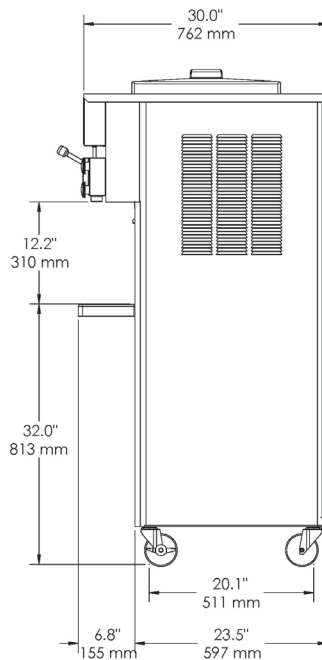
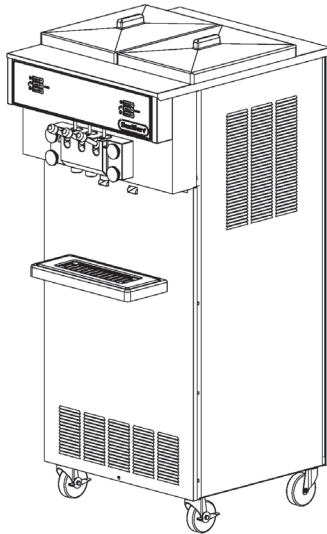

Minimum Wall Clearance  
Both Sides and Back -  
6 inches (152 mm)

ELECTRICAL				WIDTH	HEIGHT	DEPTH	WEIGHT	VOLUME
VOLTS	Hz	Ph.	Amps	INCHES (MM)	INCHES (MM)	INCHES (MM)	LBS. (Kg)	CU FT. (cu. m.)
208-230	60	1	20*	26 (660)	59.5 (1511)	30 (762)	603 (274)	
208-230	60	3	15*					
Shipping Specifications				36 (914)	65 (1650)	40 (1016)	675 (306)	54.8 (1.53)

\* Two separate circuits required.

### Specifications:

#### Cooling System:

Air or Water

#### Dasher and Compressor Motors:

(2) 1 HP Dashers  
(2) 1 HP Compressors

#### Refrigerant Type:

R404A

#### Listings:

UL, cUL, NSF

### Features:

#### Evaporator and Mix Reservoir

#### Capacity:

17 Quarts (16.15 liters) per side

#### Dasher:

Heavy-Duty Stainless Steel with low friction scraper blades.

#### Controls:

**Touch AccuFreeze** solid-state control for accurate product consistency.

#### Solid State Audio/Visual Mix Out System with Compressor Lockout

### Warranty:

Parts 1 year  
Compressor 5 years  
Evaporator 5 years

### Options:

Tune Up Kit  
Parts Tray  
Syrup Rail  
Water Cooled - 3/4" Garden Hose Fitting  
Wash Out Kit - 3/8" Flare Fitting  
Export Voltages

451 E. County Line Rd. • P.O. Box 1089 • Mooresville, IN 46158  
Toll Free 800-733-8073 • Local 317-831-7030 • Fax 317-831-7036

www.saniserv.com

REV 09.2013