



Job: _____

Item No. _____

DESIGNED FOR HIGHER VOLUME APPLICATIONS

Five – 16 oz. Servings per Minute – 20 Quart Capacity

GREAT FOR RESTAURANTS, BUFFETS, & ICE CREAM SHOPS

The **SaniServ**® model 614 Shake Freezer provides high profit, consistent quality shakes in a traditional single barrel flavor design! The 614 ease of operation is a favorite among owners and operators. The high production, capacity and recovery time insures the 614 is a perfect piece of equipment for satisfying customer demand. By adding a drink spinner and syrup rail, the 614 is sure to provide everyone's favorite shake flavor!

NEW SCROLL COMPRESSOR

Provides the **SaniServ**® Model 614 with quiet operation. It is 20% more efficient. Increased durability, with 50% longer service life.

SPACE SAVING

Compact Floor Model Design - SaniServ® model 614 provides a high volume of milk shake in the traditional floor model design.

EASY CLEANING AND OPERATION

Fewer Parts = Simplified Cleaning – SaniServ® equipment is designed and built with the fewest parts to be disassembled, cleaned and sanitized than any other machine in the industry. The state of the art solid-state **AccuFreeze**™ control insures product consistency, worry-free operation and customer satisfaction.

HIGH RETURN ON INVESTMENT

Increased Profits – SaniServ® machines combine efficiency with consistent product quality and fast, quiet operation while insuring customer satisfaction with high profit ice cream or yogurt products.

QUALITY DESIGN

Durability – SaniServ® machines are built to achieve long and dependable life through simplicity of design. Every machine is shipped standard with a stainless steel exterior, durable steel interior frame construction, heavy-duty components and consistency systems.

Model 614

Floor Model
Shake Machine
With **AccuFreeze**™ control



Made in USA

We reserve the right to change specifications and product designs without notice. Such revisions do not entitle the buyer to corresponding changes, improvements, additions or replacements for previously purchased equipment.

MODEL 614

Floor Model Shake Freezer

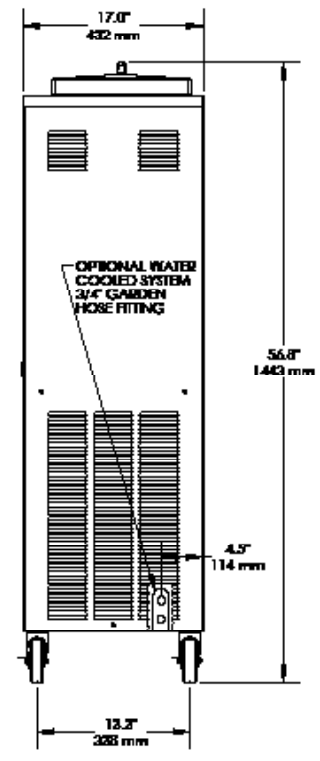
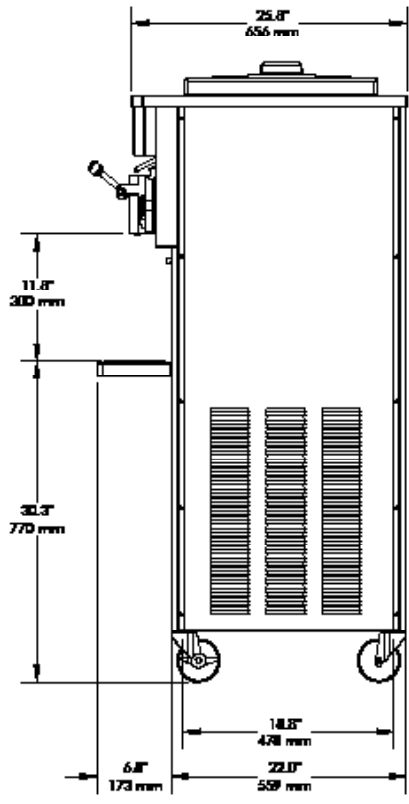
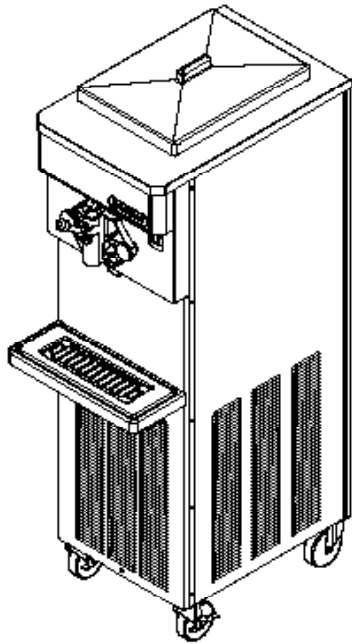

Minimum
Both Sid
6 inches (152 mm)

ELECTRICAL				WIDTH	HEIGHT	DEPTH	WEIGHT	VOLUME
VOLTS	Hz	Ph.	Amps	INCHES (MM)	INCHES (MM)	INCHES (MM)	LBS. (Kg)	CU FT. (cu. m.)
208-230	60	1	25	17 (432)	56.8 (1443)	25.8 (656)	338 (153)	
208-230	60	3	20					
Shipping Specifications				24.5 (622)	58.1 (1476)	40.5 (1029)	385 (175)	32.4 (.92)

Specifications:

Cooling System:
Air or Water

Dasher and Compressor Motors:
1/4 HP Dasher
2 HP Scroll Compressor

Refrigerant Type:
R404A

Listings:
UL, cUL, NSF

Features:

Evaporator and Mix Reservoir Capacity:
20 Quarts (18.9 liters)

Dasher:
Heavy-Duty Stainless Steel with low friction scraper blades.

Controls:
AccuFreeze™ solid-state control for accurate product consistency.

Solid State Audio/Visual Mix Out System with Compressor Lockout

Warranty:

Parts 1 year
Compressor 5 years
Evaporator 5 years

Options:

Tune Up Kit
Parts Tray
Syrup Rail
Drink Spinner
Water Cooled - 3/4" Garden Hose Fitting
Wash Out Kit - 3/8" Flare Fitting
Export Voltages