

## DD-LCG SERIES

### Low Curved Glass Deluxe Ice Cream Dipping/Display Merchandisers

#### MODELS

- DD-26LCG
- DD-46LCG
- DD-66LCG
- DD-88LCG

## FEATURES

### CONSTRUCTION

- Rounded rear stainless steel heated top improves operator comfort
- Lower back rail provides improved operator ergonomics
- Frameless double pane tempered glass viewing window, with NSF51 approved powder coated top and bottom aluminum extruded trims, provides enhanced structural stability and appearance
- Tempered glass ends improve product visibility
- Energy efficient, long lasting LED lighting
- Independent on/off light switch
- Standard electronic controller increases reliability and saves energy by maintaining consistent product temperature
- 24 gauge painted textured interior and exterior
- Stainless steel top and attached superstructure
- Stainless steel serving deck
- Equipped with leveling legs to correct for unlevel flooring situations
- Drain with garden hose connector for ease of cleaning

- Heavy-duty epoxy-coated wire can support racks
- 3" thick walls and 2 1/2" floor with foamed-in-place "zero ODP" urethane insulation

### LIDS

- Hinged, high-tensile, transparent acrylic dipping compartment lids with full length handle

### REFRIGERATION

- Eco-friendly R290 refrigerant
- Cold wall evaporator
- Low maintenance condenser coil
- Condenser filter screen, removable without tools, for easy condenser coil cleaning resulting in peak efficiency and extended equipment life (DD-66LCG & DD-88LCG models). Screen should be cleaned every three months depending on operating environment.
- Rear air intake with rear and side discharge eliminates front grille and allows full front of cabinet for graphics
- Side compartment grille improves the air circulation and accessibility during servicing

- No minimum clearance required on cabinet sides but front, back and top must be left open for customer and operator access
- Temperature range: 5° to -5°F (-15° to -21°C)
- R-factor (insulation efficiency rating): 19.40

### WARRANTY

- Standard limited two year parts and labor
- Additional three year coverage on compressor part

## OPTIONS

- Removable can holders with white overnight can covers
- Dipper well
- Removable frost shields
- Leg kit
- Casters
- Lid locking kit (less locks, requires one kit per lid)



# DD-LCG SERIES

## LOW CURVED GLASS DELUXE ICE CREAM DIPPING/DISPLAY MERCHANDISERS

### TECHNICAL SPECIFICATIONS

MODEL	DIMENSIONS (in.)			DIMENSIONS (mm)			VOLTS	AMPS	UNIT H.P.	CAN CAPACITY* DISPLAY/STORAGE	SHIP CU. FT.	SHIP WT. LB/KG
	L	D	H	L	D	H						
DD-26LCG	27 1/4	27 1/2	50	692	699	1270	115	5.9	3/5	4/0	41.8	264/120
DD-46LCG	48 1/4	27 1/2	50	1226	699	1270	115	5.9	3/5	8/4	59.4	407/184
DD-66LCG	69 1/4	27 1/2	50	1759	699	1270	115	7.2	5/6	12/8	83.6	545/248
DD-88LCG	90 1/4	27 1/2	50	2292	699	1270	115	7.2	5/6	16/12	106.7	660/300

\*Capacities in 9 1/2" diameter, 3 gallon cans.

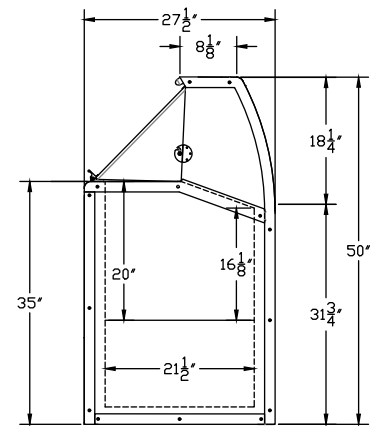
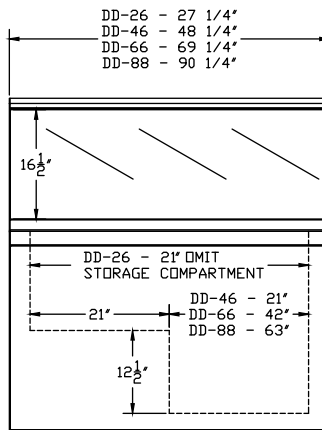
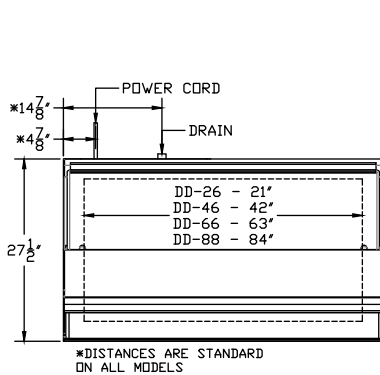

### LISTINGS



### HOOKUP

Via plug in, 10 foot long, flexible 3 wire 16/3 cord with molded plug. Drain hookup has standard garden hose connection.



### BID SPECIFICATIONS

Item no. DD-\_\_\_\_ LCG  
 Provide \_\_\_\_\_ ( ) Low Curved Glass Deluxe Ice Cream Dipping/Display Merchandiser(s), Master-Bilt® model no. DD-\_\_\_\_ LCG.  
 Cabinet will feature textured finish on interior and exterior.  
 Cabinet to be constructed of 24 gauge painted textured interior and exterior with a stainless steel top and attached superstructure as well as a stainless steel serving deck.  
 Cabinet to be provided with rounded rear

stainless steel heated top and lower back rail for improved operator ergonomics. The viewing window will be constructed of frameless tempered glass with NSF51 approved powder coated top and bottom aluminum extruded trim.  
 Interior LED lighting controlled by an independent on/off switch. Cabinet to have rear air intake with rear and side discharge.  
 Hinged lids composed of high-tensile, transparent acrylic with full length handle.  
 Hanging frost shields with mounting

screws offered as an option.  
 Refrigerant will be R290 and temperature range will be 5° to -5°F (-15° to -21°C). Cabinet refrigeration system will contain a low maintenance condenser coil.  
 Cabinet to have standard limited two year parts and labor warranty with additional three year coverage on compressor part.  
 Cabinet to be UL and C-UL listed and UL EPH classified.

NOTE: Cabinet designed for optimum performance in air-conditioned area at 75°F ambient and 55% relative humidity. All specifications subject to change without notice.



727 Second Street • Hudson, WI 54016  
800-647-1284 • master-bilt.com