



Note: Pumps, jars and spoons are not included in the base model.

## FLR SERIES

### Flavorail Ice Cream Dipping Cabinets

#### MODELS

- FLR-60
- FLR-80

## FEATURES

### CONSTRUCTION

- 20 gauge seamless stainless steel top
- 24 gauge painted textured steel exterior
- Galvanized steel inner liner with copper tube wrap cold wall evaporator
- Anti-condensate heaters under stainless top cap
- 2 1/4" foamed-in-place "zero ODP" urethane insulation
- Equipped with leveling legs to correct for unlevel flooring situations
- Floor drain with standard garden hose fitting

### LIDS

- Stainless steel
- Hinged with handles
- Heavy-duty replaceable gasket

### REFRIGERATION

- Refrigerant: R290
- Self-contained, slide-out, factory tested refrigeration system
- Forced draft hermetic condensing unit
- Minimum 4" clearance required between cabinet back and wall
- Temperature range: 10° to -10°F (-12° to -23°C)
- R-factor (insulation efficiency rating): 19.40

### WARRANTY

- Standard limited two year parts and labor
- Additional three year coverage on compressor part

## OPTIONS

- Add suffix "SE" for all stainless exterior
- Pumps and jar assemblies
- Lid locking kit (less lock)
- Casters
- Legs
- Individual pumps, jars, hinged jar lids and ladles
- Dipper well



# FLR SERIES FLAVORAIL ICE CREAM DIPPING CABINETS

## TECHNICAL SPECIFICATIONS

MODEL	DIMENSIONS (in.)			DIMENSIONS (mm)			VOLTS	AMPS	UNIT H.P.	CAN CAPACITY DISPLAY/STORAGE*	CAP. CU. FT.	SHIP CU. FT.	SHIP WT. LB/KG
	L	D	H	L	D	H							
FLR-60	43	30 <sup>1</sup> / <sub>8</sub>	38 <sup>1</sup> / <sub>4</sub>	1092	765	972	115	3.2	1/4	5/7	12.5	46.0	300/136
FLR-80	54	30 <sup>1</sup> / <sub>8</sub>	38 <sup>1</sup> / <sub>4</sub>	1372	765	972	115	3.6	1/3	6/11	16.8	57.0	340/155

\*Capacity measured in 3 gallon cans.

### FLR-60

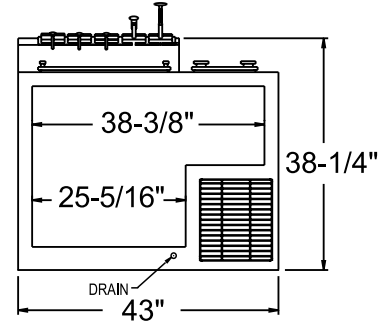
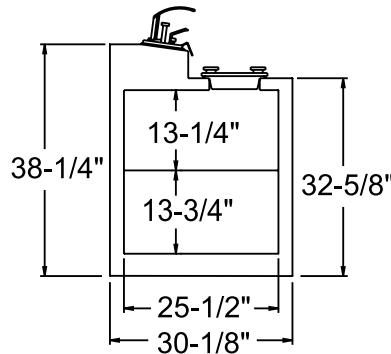
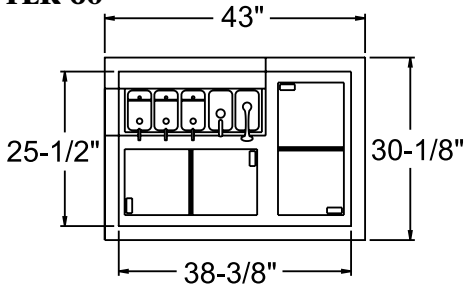

### FLR-80

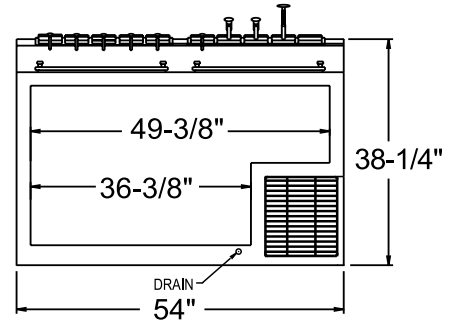
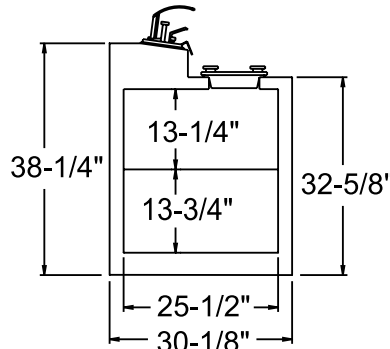
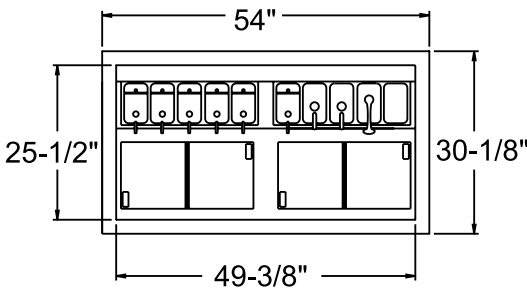

PLAN VIEW

SIDE VIEW

ELEVATION VIEW

**Note: Pumps, jars and spoons are not included in the base model.**

## LISTINGS



## HOOKUP

Via plug in, 8 foot long, flexible 3 wire 14/3 cord with molded plug. 15 amp service is recommended.



## BID SPECIFICATIONS

Item no. FLR-\_\_\_\_\_  
Provide \_\_\_\_\_ ( ) Flavorail Ice Cream Dipping Cabinet(s), Master-Bilt® model no. FLR-\_\_\_\_\_.

Cabinet to feature textured finish on exterior with galvanized steel interior. Other standard features include anti-

condensate heaters under stainless top cap, 2<sup>1</sup>/<sub>4</sub>" foamed-in-place "zero ODP" urethane insulation and stainless steel lids hinged with handles. Standard leveling legs provided to correct for unlevel flooring situations.

The refrigeration system is to be self-

contained and use R290 refrigerant. The temperature range will be 10° to -10°F (-12° to -23°C). Cabinet to have standard limited two year parts and labor with additional three year coverage on compressor part. Cabinet to be UL, C-UL and NSF listed.

**NOTE: Cabinet designed for optimum performance in air-conditioned area at 75°F ambient and 55% relative humidity. All specifications subject to change without notice.**



727 Second Street • Hudson, WI 54016  
800-647-1284 • master-bilt.com